

EZL-200F User's Manual

Version 1.7



Sollae Systems Inc.



To all residents of the European Union

Important environmental information about this product

This symbol on this unit or the package indicates that disposal of this unit after its lifecycle could harm the environment. Do not dispose of the unit as unsorted municipal waste; it should be brought to a specialized company for recycling. It is your responsibility to return this unit to your local recycling service. Respect your local environmental regulation. If in doubt, contact your local waste disposal authorities.

-Table of Contents –

1. OVERVIEW	- 6 -
1.1. OVERVIEW	- 6 -
1.2. APPLICATIONS	- 7 -
1.2.1. <i>Remote monitoring and Control</i>	- 7 -
1.2.2. <i>SSL/SSH Secure Communications</i>	- 7 -
1.2.3. <i>Multi-Monitoring</i>	- 8 -
1.2.4. <i>Serial Tunneling</i>	- 8 -
1.2.5. <i>A simple router by SLIP function</i>	- 9 -
2. SPECIFICATIONS	- 10 -
2.1. SPECIFICATIONS	- 10 -
2.2. INTERFACE	- 11 -
2.2.1. <i>Power</i>	- 11 -
2.2.2. <i>Dsub Connector</i>	- 11 -
2.2.3. <i>Status LEDs</i>	- 13 -
2.2.4. <i>Ethernet Interface</i>	- 13 -
3. INSTALLATION AND TEST RUN	- 14 -
3.1. INSTALLATION METHOD.....	- 14 -
3.1.1. <i>Checking the Communication Environment</i>	- 14 -
3.1.2. <i>Connecting to the Network</i>	- 15 -
3.1.3. <i>Configuring the Environmental Variables</i>	- 15 -
3.2. TEST RUN.....	- 15 -
3.2.1. <i>Changing PC IP Address</i>	- 15 -
3.2.2. <i>Installing EZL-200F</i>	- 15 -
3.2.3. <i>Configuring EZL-200F</i>	- 15 -
3.2.4. <i>Connecting to the PC Serial Port</i>	- 16 -
3.2.5. <i>Communication Test</i>	- 16 -
4. CONFIGURING IP ADDRESS AND ENVIRONMENTAL VARIABLES	- 17 -
4.1. IP ADDRESS AND ENVIRONMENTAL VARIABLES	- 17 -
4.2. CONFIGURATION BY EZCONFIG	- 22 -
4.2.1. <i>ezConfig Menus</i>	- 22 -
4.2.2. <i>Example configuration of ezConfig</i>	- 23 -
4.3. CONFIGURATION USING TELNET	- 25 -
4.3.1. <i>Example of Configuration using Telnet</i>	- 25 -

4.3.2.	<i>Configuration Commands by telnet</i>	- 28 -
4.4.	AT COMMAND.....	- 29 -
4.5.	SETTING IP ADDRESS BY ARP.....	- 30 -
4.5.1.	<i>Setting of EZL-200F's IP address in Windows</i>	- 30 -
4.5.2.	<i>Setting of EZL-200F's IP address in Linux</i>	- 30 -
4.6.	SETTING IP ADDRESS-RELATED ITEMS BY DHCP.....	- 31 -
4.7.	SETTING IP ADDRESS-RELATED ITEMS BY PPPoE	- 31 -
5.	OPERATION MODE	- 32 -
5.1.	OPERATION MODE OVERVIEW	- 32 -
5.1.1.	<i>Overview</i>	- 32 -
5.2.	HOW TO INITIATE EACH OPERATION MODE.....	- 32 -
5.2.1.	<i>How to Initiate Normal Mode</i>	- 32 -
5.2.2.	<i>How to Initiate Console Mode</i>	- 32 -
5.2.3.	<i>How to Initiate ISP Mode</i>	- 33 -
5.2.4.	<i>Comparison of Operation Modes</i>	- 33 -
5.3.	NORMAL COMMUNICATION MODE.....	- 33 -
5.4.	CONSOLE MODE.....	- 34 -
5.5.	ISP MODE	- 34 -
6.	NORMAL COMMUNICATION MODE	- 37 -
6.1.	T2S (TCP TO SERIAL).....	- 37 -
6.2.	ATC (AT COMMAND).....	- 39 -
6.3.	COD (CONNECT ON DEMAND).....	- 41 -
6.4.	U2S (UDP TO SERIAL).....	- 43 -
7.	ATC MODE	- 45 -
7.1.	OVERVIEW	- 45 -
7.1.1.	<i>AT command format</i>	- 45 -
7.2.	BASIC AT COMMAND SET (EXAMPLE: ATA, ATD ETC.)	- 45 -
7.3.	EXTENDED AT COMMANDS (EXAMPLE: AT+PLIP ETC.)	- 46 -
7.4.	ONLINE STATE AND ONLINE COMMAND STATE	- 46 -
7.4.1.	<i>Changing Online State to Online Command State</i>	- 46 -
7.4.2.	<i>Changing Online Command State to Online State</i>	- 47 -
7.5.	EXAMPLE OF CONFIGURATION WITH AT COMMAND	- 47 -
7.6.	EXAMPLE OF TCP CONNECTION	- 47 -
7.6.1.	<i>Example of Active Connection</i>	- 47 -

7.6.2.	<i>Example of passive Connection</i>	- 48 -
7.7.	EXAMPLE OF TCP DISCONNECTION	- 48 -
7.7.1.	<i>Example of active disconnection</i>	- 48 -
7.7.2.	<i>Example of passive disconnection</i>	- 48 -
8.	OTHER FUNCTIONS	- 49 -
8.1.	SSL.....	- 49 -
8.2.	SSH	- 49 -
8.3.	TELNET COM PORT OPTION	- 49 -
8.4.	PING TEST	- 50 -
8.5.	DESIGNATING TCP TX BLOCK	- 50 -
8.6.	SETTING COD DELAY IN COD MODE	- 51 -
8.7.	MULTI-CONNECTION	- 51 -
8.8.	SLIP FUNCTION	- 51 -
8.8.1.	<i>Configuring SLIP</i>	- 51 -
8.8.2.	<i>Configuring Hosts</i>	- 51 -
9.	TECHNICAL SUPPORT, WARRANTY, AND NOTES ON OPERATION.....	- 52 -
9.1.	TECHNICAL SUPPORT	- 52 -
9.2.	WARRANTY	- 52 -
9.2.1.	<i>Refund</i>	- 52 -
9.2.2.	<i>Free Repair Services</i>	- 52 -
9.2.3.	<i>Charged Repair Services</i>	- 52 -
9.2.4.	<i>Notes on Operation</i>	- 52 -
10.	DOCUMENT REVISION HISTORY	- 54 -

1. Overview

1.1. Overview

Along with the development of the Internet, the demand for data communication functions has increased recently. Data communication over the Internet requires using TCP/IP, the Internet communication protocol. That is to say, in order to connect a system to the Internet, TCP/IP protocol must be implemented. It is possible to implement TCP/IP by directly implementing the protocol, porting public TCP/IP, or using Operating System (OS). However, all these methods impose burdens on the developer in time, cost, and technology.

ezTCP series, a Serial ↔ TCP/IP protocol converter product group of Sollae Systems, enables you to use TCP/IP communication (the Internet communication) function simply by “connecting the cable to a serial port”. ezTCP sends data from the serial port to the Internet network after TCP/IP processing, and vice versa.

EZL-200F in ezTCP product group is a product that provides TCP/IP communication through Ethernet. In other words, like other ezTCP products, EZL-200F sends data from the serial port to the LAN after TCP/IP processing and vice versa.

As supporting RS-422, and RS485 as well as RS-232 for serial ports, EZL-200F can be connected to various systems. And it also supports RFC2217 function that provides RS-232 control signal transmission.

It provides DHCP and PPPoE functions, so that it can be applied to the cable network and the xDSL network.

As EZL-200F provides SSL security function and SSH login function, it can be used in a system that requires a high level of security. And it also provides Multi-monitoring function, so several hosts can communicate with EZL-200F at the same time.

EZL-200F provides a simple router function, so user can connect their hosts that are in the different network via serial.

1.2. Applications

1.2.1. Remote monitoring and Control

User can communicate RS232, RS422 or RS485 devices by EZL-200F. As Most of devices have RS232, RS422, or RS485 interface for communication, User can apply EZL-200F to most of devices.

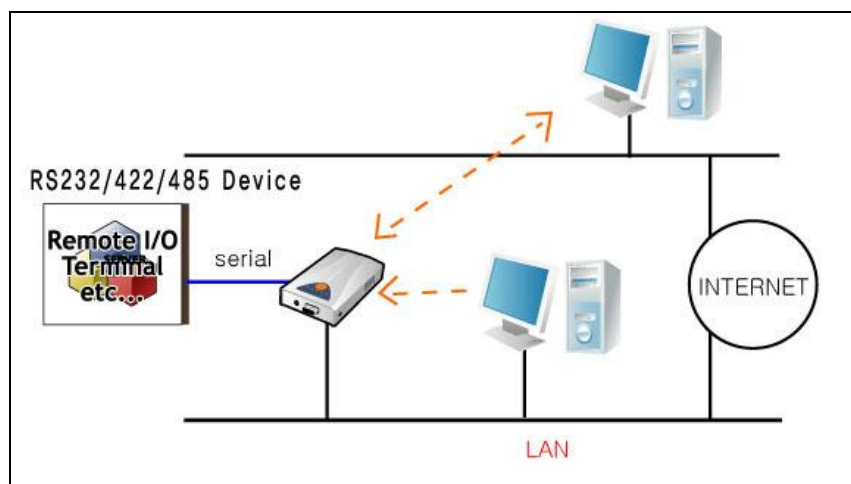

1.2.2. SSL/SSH Secure Communications

As EZL-200F support an SSL function, it can be applicable to systems that require security. It also supports SSH login function, so it provides more powerful security function.

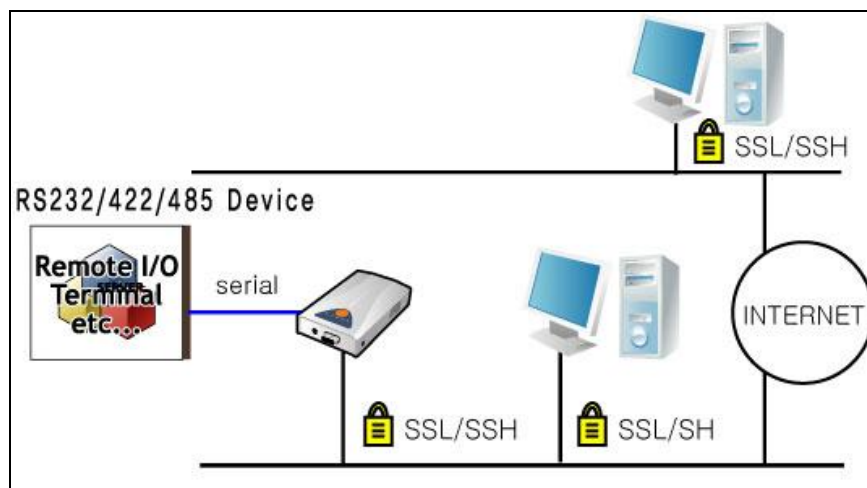

1.2.3. Multi-Monitoring

Up to 8 hosts can connect to an EZL-200F at the same time. So it is very useful to multi-user systems.

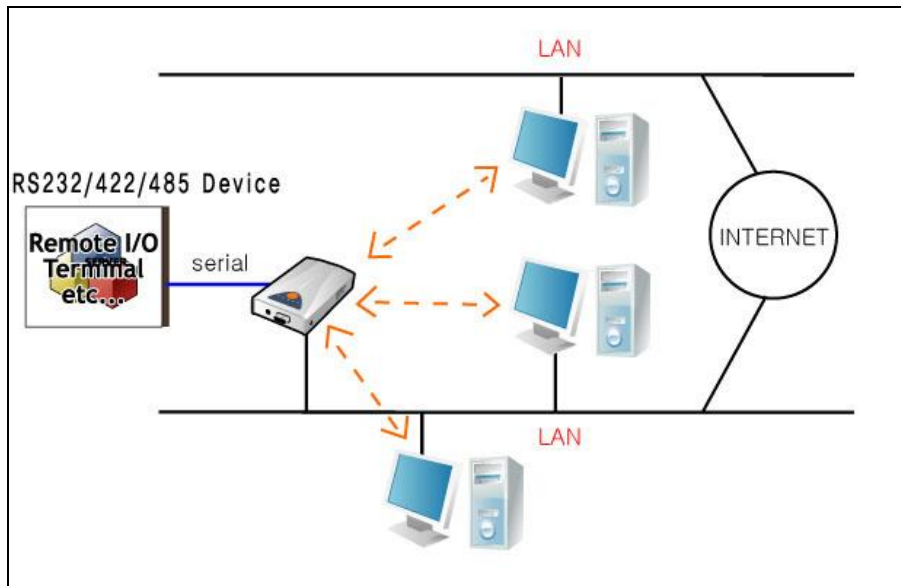

1.2.4. Serial Tunneling

If user wants to connect two serial devices each other for a long distance, EZL-200F are suitable. Because it supplies Telnet COM Port Option that is defined RFC2217. The Telnet COM Port Option provides RS232 control signal transmission function.

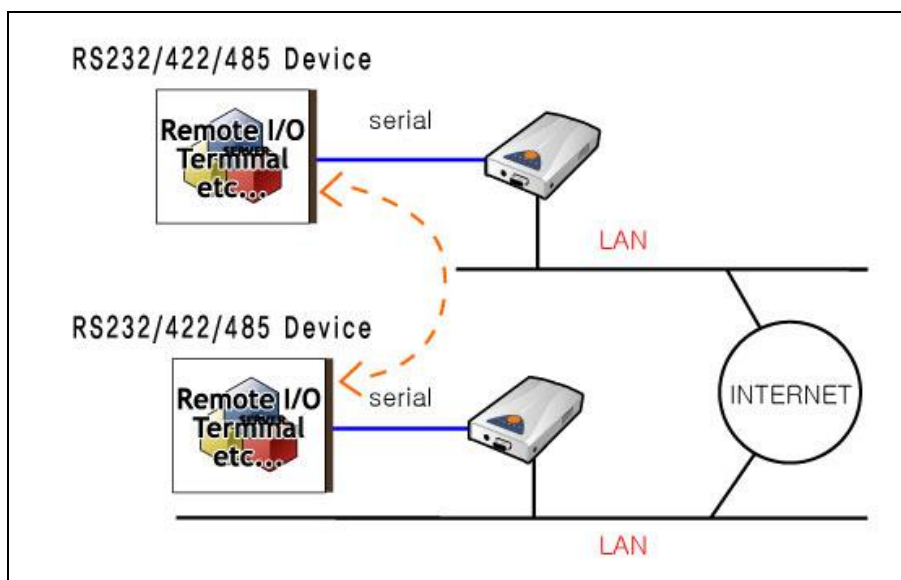

1.2.5. A simple router by SLIP function

User can connect two Ethernet networks by using two EZL-200F's SLIP function. If EZL-200F is set as SLIP, it operates as a simple router via its RS232 or RS485 line.

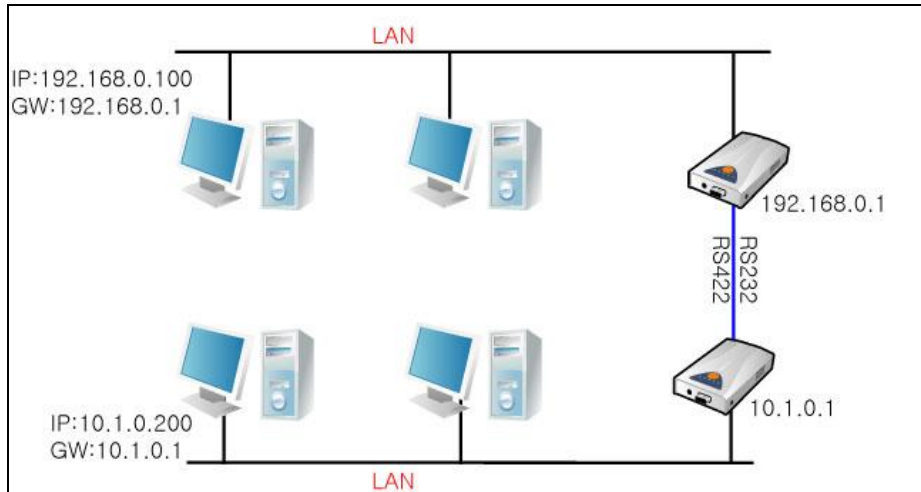

2. Specifications

- EZL-200F Body
- 5V Power Adopter (Option)
- RS232C cable for PC connection (Option)

2.1. Specifications

Power	Input Voltage	5V ($\pm 10\%$)
	Current	320mA typical
Dimension	136mm x 83mm x 29mm	
Weight	About 140g	
Interface	Serial	9pin Dsub male
	Network	10/100 Base T
Serial Port	RS232 / RS422(full duplex) / RS485 (half duplex) (1200bps ~ 115200bps)	
Network	Ethernet 10/100 M bit auto-sense Auto MDI/MDIX	
Protocols	TCP, UDP, IP, ICMP, ARP, DHCP, PPPoE SSL 3.0 / TLS 1.0, SSH, SLIP, Telnet COM Port Option(RFC2217)	
Communication Mode	T2S	TCP Server Mode
	COD	TCP Client Mode
	ATC	TCP Server/Client (AT command emulation)
	U2S	UDP
Utilities	ezConfig	Configuration utility via LAN
	ezterm	Socket test utility
	hotflash	Firmware download utility via TFTP
	ezVSP	Serial-TCP/IP virtual driver for Windows

☞ You can download free utilities and firmware from <http://www.eztcp.com>.

2.2. Interface

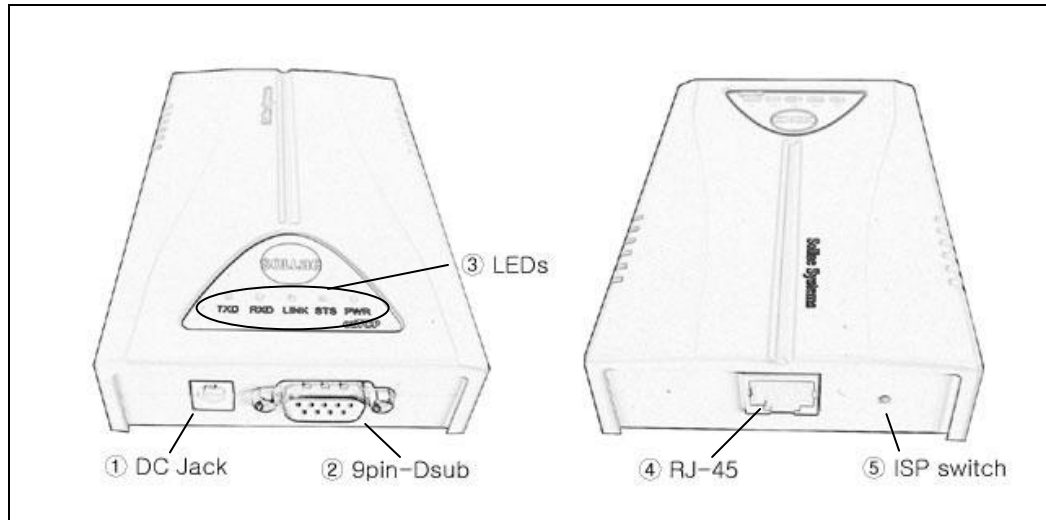

2.2.1. Power

DC 5V is used for EZL-200F and the specification is below:

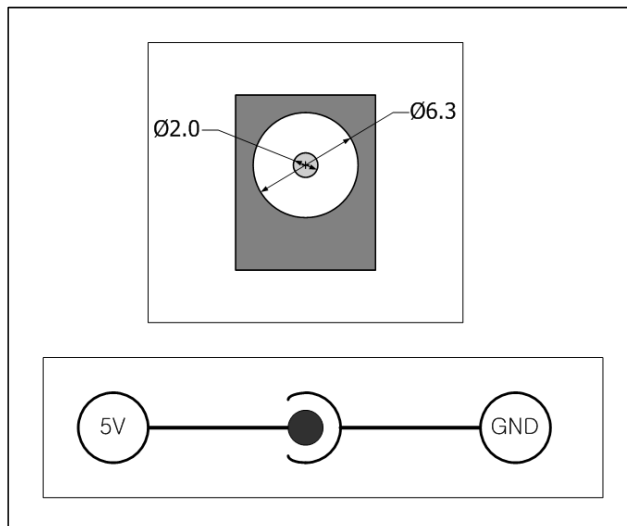

2.2.2. Dsub Connector

The connector of serial port is 9 pin Dsub male. The specification is below:

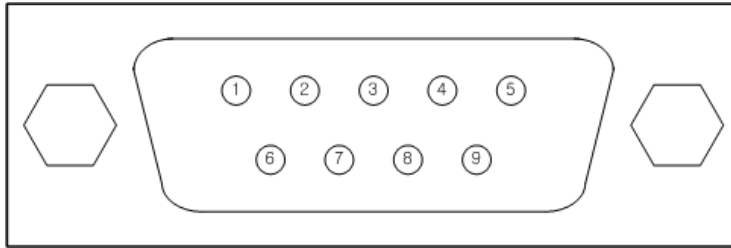

- RS-232

number	name	description	level	Dir.	Etc.
1	DCD	Data Carrier Detect	RS232	Input	Mandatory
2	RXD	Receive Data	RS232	Input	Mandatory
3	TXD	Transmit Data	RS232	Output	Mandatory
4	DTR	Data Terminal Ready	RS232	Output	Optional
5	GND	Ground	Ground	-	Mandatory
6	DSR	Data Set Ready	RS232	Input	Optional
7	RTS	Request To Send	RS232	Output	Optional
8	CTS	Clear To Send	RS232	Input	Optional
9	RI	Ring Indicator	RS232	Input	Optional

- RS-422 (full duplex)

number	name	description	level	Dir.	Etc.
9	TX+	Transmit Data +	Differential	Output	Mandatory
1	TX-	Transmit Data -			
4	RX+	Receive Data +	Differential	Input	
3	RX-	Receive Data -			

- RS-485(half duplex)

number	name	description	level	Dir.	Etc.
9	TRX+	Data +	Differential	Input/Output	Mandatory
1	TRX-	Data -			

2.2.3. Status LEDs

EZL-200F has 5 LEDs.

Each LED functions as follows:

Name	Meaning	Color	LED Status	Description
PWR	Power	Red	ON	Power is supplied.
STS	Status	Yellow	Blinking for a Sec	IP is allocated but TCP connection is not established.
			Blinking 4 Times/Sec	IP is not allocated.
			ON	TCP connection is established.
			Rapidly Blinking	Console mode
LINK	LAN Link	Green	ON	Connected to 100M network.
			Blinking	There are data on the LAN when EZL-200F is connected to 100M
		Red	ON	Connected to 10M network.
			Blinking	There are data on the LAN when EZL-200F is connected to 10M.
RXD	LAN Rx	Yellow	Blinking	There are data on the LAN
TXD	LAN Tx	Green	Blinking	Packets are being transmitted to Ethernet

2.2.4. Ethernet Interface

Network part of EZL-200F is configured with Ethernet. So, what you have to do is only to connect UTP cable. The Ethernet part detects 10Mbit or 100Mbit Ethernet automatically, to connect the corresponding cable. It also provides auto MDI/MDIX function to automatically detect 1:1 cable or cross-over cable.

Each piece of Ethernet equipment has unique hardware addresses, and EZL-200F also has factory-set hardware address (which is called MAC address).

3. Installation and Test Run

3.1. Installation Method

You can install EZL-200F in the following steps.

Title	Item	Sub-item	Description
1. Checking the communication environment	Check items	IP address environment	4.1.
		Serial port settings	4.1.
		Application program to be used	6.
2. Connecting to the network	Check method	Check if LINK LED is ON.	2.3.3.
3. Configuring the environmental variables	Configuration method	Set by ezConfig, a utility program for configuration through the network.	4.2.
		Set by AT commands in ATC mode	4.4.
		By ARP (Temporarily set IP address only)	4.5.
	Configuration items	IP address related items	4.1.
		Serial port related items	4.1.
		Communication mode (Decided depending on application program)	6.
4. Application to the field			

3.1.1. Checking the Communication Environment

Before installing EZL-200F, check the network environment where EZL-200F is to be installed, including the followings matters:

- IP address environment (local IP, subnet mask, gateway, etc.)
- Serial port type of the equipment to which EZL-200F is going to be connected (RS232, RS422, RS485)
- Serial port items of the equipment to which EZL-200F is going to be connected (baud rate, data bit, parity, stop bit)
- Application program protocol to be used (TCP/UDP, server/client, SSL, etc.)

☞ For application program protocol to be used, see "6. Normal Communication

Mode".

3.1.2. Connecting to the Network

Connect power to EZL-200F, and connect EZL-200F either directly to the Ethernet port of the PC where test is to be performed or to the network (hub) to which the PC is connected.

3.1.3. Configuring the Environmental Variables

When network connection is completed, configure the environmental variables such as IP address related items, serial port related items, and communication mode related items through the LAN using "ezConfig," the environmental variable configuration program.

☞ *For environmental variable configuration, see "4. Setting IP Address and Environmental Variables."*

3.2. Test Run

You can perform test run according to the following orders. The test run described here is based on the assumption that the IP address of the PC is set to 10.1.0.2 and its serial interface is configured as RS232 interface.

3.2.1. Changing PC IP Address

You can change the IP address of your PC as follows:

IP Address	10.1.0.2
Subnet Mask	255.0.0.0
Gateway IP Address	0.0.0.0

3.2.2. Installing EZL-200F

Connect the supplied RS232 cable between your PC and EZL-200F, the LAN cable to the hub to which the PC is connected or directly to the PC, and the supplied EZL-200F power adapter to EZL-200F for power supply. If the LAN cable has been correctly connected when power is supplied, LINK LED turns on.

3.2.3. Configuring EZL-200F

Configure EZL-200F setting using ezConfig, the ezTCP configuration program, as follows.

Run ezConfig, and click [Search ezTCP] button in the ezConfig window. And, ezConfig program will search all ezTCPs on the local network.

When ezTCP is searched, MAC address of the ezTCP is displayed on the [Search List] window (The MAC address is indicated at the bottom of the product case).

Select the corresponding MAC address, and set the same as shown in the following figure and click [Write] button to save the settings.

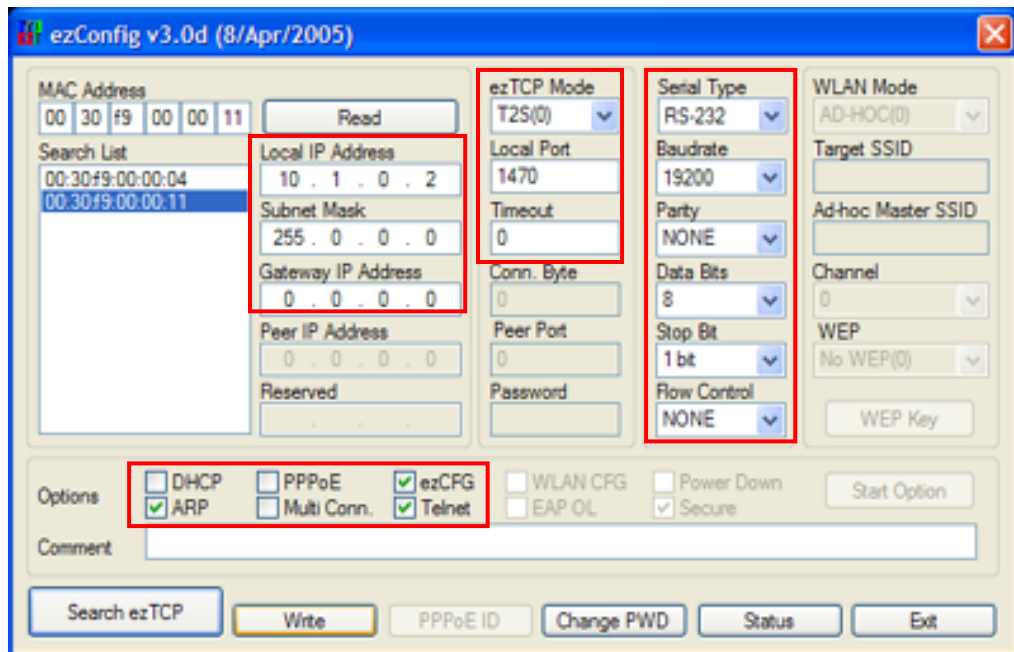

3.2.4. Connecting to the PC Serial Port

Connect the serial port of your PC and that of EZL-200F, using the supplied serial communication cable. Then, run serial communication program such as Hyper Terminal and Teraterm. When the program is run, select the same serial port values as those set to EZL-200F [19200bps, data bit: 8 bits, stop bit: 1 bit, no parity], which will finish the preparation for serial communication.

3.2.5. Communication Test

When the preparation for serial communication is finished, enter the following in the DOS window on your PC, to connect to TCP through Telnet program.

```
“Telnet 10.1.0.1 1470”
```

When TCP connection succeeds, STS LED of EZL-200F turns ON.

When the STS LED turns ON, enter “123” on the Telnet window, and “123” will appear on the hyper terminal. Enter “ABC” on the hyper terminal, and “ABC” will appear on the Telnet window. Otherwise, communication test fails.

4. Configuring IP Address and Environmental Variables

4.1. IP Address and Environmental Variables

For TCP/IP communication, you must set IP address related items. In addition, you have to set serial port related items (serial port type, communication speed, data bit length, parity bit, flow control, etc) to EZL-200F.

You can set the IP address and the serial port related items by using ezConfig, the supplied configuration utility which allows you to configure your EZL-200F over the network, by logging in Telnet, or by using AT commands in ATC mode. Also, you can set IP address temporarily, using ARP method which uses MAC address (hardware address).

	Item	Description
IP Address-related Items	Local IP Address	IP address of EZL-200F
	Subnet Mask	Subnet mask
	Gateway IP Address	IP address of gateway
	Local Port	Port number for waiting to be connected in Server mode Port number for waiting UDP data
	Peer IP Address	IP address to connect in Client mode IP address to send data in UDP mode
	Peer Port	Port number to connect in Client mode Port number to send data in UDP mode
	DHCP	Select to receive EZL-200F IP address as DHCP.
	PPPoE	Select to receive EZL-200F IP address as PPPoE.
	PPPoE ID & Password	ID and password to be used for PPPoE
Serial Port	Serial Type	Serial port type(RS232,RS422,RS485)
	Baud Rate	Serial port speed (bps)
	Data Bits	Data bit length

	Parity	Parity
	Stop Bit	Stop bit
	Flow Control	Flow control
Communication Mode	ezTCP Mode	Communication mode
Connect/Disconnect Event	Conn. Byte	Minimum number of bytes attempting to connect/transmit
	COD DELAY	Reconnect time when COD connection is closed (unit: seconds)
	Timeout	Limit time to keep connection
Configuration Method Used	ezConfig	Enable ezConfig function.
	Telnet	Enable Telnet log in function
	SSH	Login to the console with SSH
	Password	Set Telnet, SSH and ezConfig password.
	ARP	Enable IP setting by ARP.
Other Functions	SSL	Enable SSL security feature.
	SLIP	A router function by using SLIP
	TELCOM	RS232 control signal transmission function that is defined by RFC2217
	MAC ID	EZL-200F transmits its MAC address as soon as TCP connection is established. (T2S, COD only)
	SEND DEALY	TCP data transmission interval (unit: ms)
	Comment	User comment on the product
	Multi Conn.	Multi-connection (T2S only)

- Local IP Address

IP address of EZL-200F. If you set DHCP or PPPoE, an IP address is automatically allocated.

- Subnet Mask

Sets subnet mask of the network where EZL-200F is installed

- Gateway IP Address

Sets the gateway IP address of the network where EZL-200F is installed.

- Local Port

Port number, which is used as TCP port number waiting to be connected when EZL-200F operates as TCP server or as the port number waiting for UDP data when it operates in U2S communication mode.

- Peer Port

Local port number of the server to connect when EZL-200F operates as TCP client or to transmit UDP data when it operates as U2S

- Serial Type

Selects a serial port interface of EZL-200F, among RS232, RS422 (full duplex), and RS485 (half duplex) interfaces.

- Baud Rate

Selects a serial port speed (1200 bps ~ 115200bps).

- Data Bits

Selects a data bit length of the serial port (7 bits or 8 bits)

- Parity

Select a parity bit of the serial port (None, Even, Odd, Mark, Space).

- Stop Bit

Selects a stop bit length of the serial port (1 bit, 2 bits).

- Flow Control

Selects flow control for the serial port (None, RTS/CTS, Xon/Xoff).

- ezTCP Mode

Selects the communication mode of EZL-200F (T2S, ATC, COD, U2S).

- Conn. Byte

Decides a point of time to start connection when EZL-200F operates as COD. EZL-200F starts to connect to the host (Peer IP Address and Peer Port) of the designated host upon receiving as many data as specified by [Conn. Byte] from the serial port.

- Block (Byte)

Decides the size of UDP packet to be sent at a time when EZL-200F operates as U2S.

- COD Delay – Possible to set using Telnet (See 3.3).

Time after connection is off as Conn. Byte is 0 in COD mode until connection is reestablished (unit: second)

- Timeout

When EZL-200F operates as TCP such as T2S, COD and ATC, connection is closed if data communication is not continued as long as the time set to this item unless this item is set to 0 (unit: second)

- Interval

When EZL-200F operates as UDP like U2S, it transmits data in blocks by gathering data for the time set to this item (unit: 10ms)

- ezConfig

You can use ezConfig utility only this item is enabled.

(If this item is not enabled, you cannot set EZL-200F using ezConfig. Therefore, it is recommended to enable this all the times.)

- Telnet

Only when this item is enabled, you can log in Telnet, to control or check EZL-200F through the EZL-200F console.

- Password

Sets a password for configuring with ezConfig or logging with Telnet.

- ARP

Sets whether to or not to set IP address using ARP protocol. When this item is selected, EZL-200F uses the destination IP address of the first packet coming to its MAC address as its own IP address temporarily.

- DHCP

Set to receive an IP address as DHCP.

- PPPoE

Set to receive an IP address as PPPoE.

- PPPoE ID & Password

Sets ID and password used for PPPoE.

EZL-200F uses maximum 32 byte for saving an ID and 8 bytes for a password.

- SSL – Possible to set using Telnet (See 3.3)

Enabled when SSL is used.

- SSH

When this item is set, User login EZL-200F by SSH client not telnet client. Its ID is 'admin' and password is the password that is set on the password item.

- Send Delay – Possible to set using Telnet

Sets the time to gather data from the serial port, when transmitting TCP data (unit: ms, minimum setting: 20). If this item is set to 0, the send delay works as 20ms.

- Comment

Stores maximum 32 byte user comment on the product. This item helps the user distinguish each EZL-200F more easily.

- Multi Conn.

Enabled to support maximum 8 multiple connections in T2S mode. All connected hosts can exchange data with each other.

- SLIP

EZL-200F operates as a simple router. It relays two Ethernet networks by using two EZL-200Fs. The serial ports between two EZL-200Fs use SLIP.

- TELCOM – Telnet COM Port Option

EZL-200F sends its serial port information to the host that is connected to it and EZL-200F outputs the control signal that is received from the host to its serial port.

- MAC ID

EZL-200F sends its MAC address to the peer host as soon as the TCP connection is established. This function operates only in the T2S and COD mode.

4.2. Configuration by ezConfig

4.2.1. ezConfig Menus

The basic environmental variables (IP address related items, serial port items, and etc.) can be set by ezConfig which is an integrated management tool for Windows.

ezConfig is operated in Microsoft Windows(Windows 98, 98 SE, 2000 Pro, ME, XP Pro/Home). Following is the screen shot of ezConfig which is just launched.

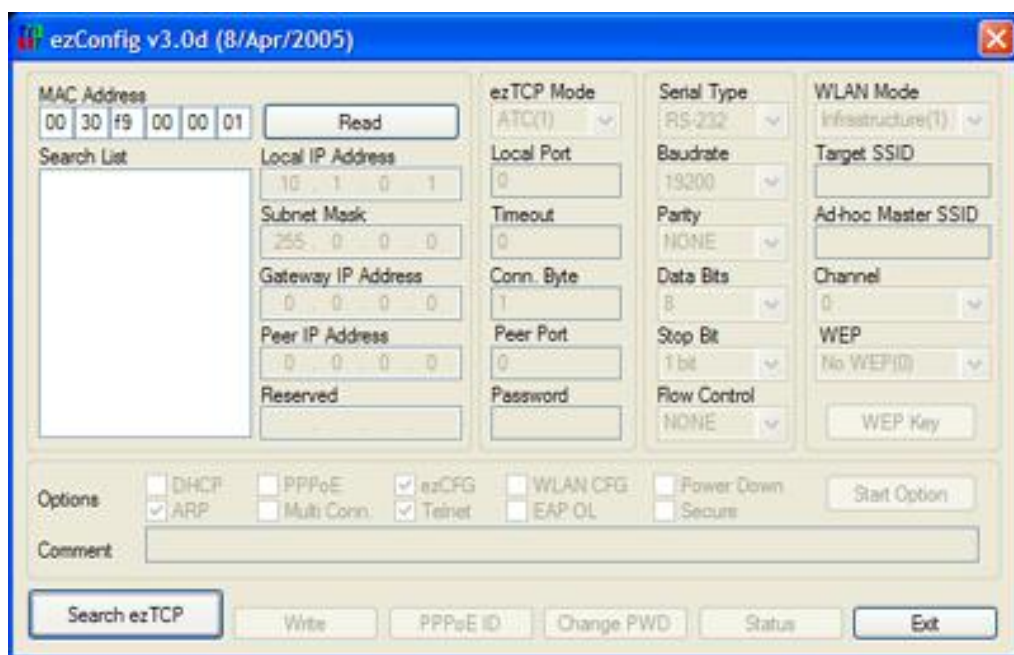

√ ezConfig can set not only EZL-200F's environmental variables but also other ezTCP series.

The functions of ezConfig's buttons are followed:

This button is used to search for all of the network-attached ezTCPS. The search results will be displayed on the [Search List] box and you can select an item using a mouse or cursor as required. The value displayed on the box indicates the MAC ADDRESS of each ezTCP. The selected setup value of ezTCP will be displayed on the right side.

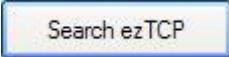

You can see only the ezTCP configuration values if you press this button after entering the 6-digit hexadecimal number printed on the ezTCP main body in the MAC ADDRESS box. It is useful when there are too many ezTCPs attached to the network to search for one from the LIST box.



This button is used to save the changed value in ezTCP after modifying the configuration. Make sure not to press this button during operating ezTCP since ezTCP will automatically be reset right after its environment setup value is saved. Otherwise, it may cause malfunction.



This button is used to close ezConfig. You can also close it by pressing ESC key on the keyboard.



ezTCP provides User Authentication function to prevent an unwanted person from modifying the configuration. The authentication process is performed through the password string verification. When entering or changing the password strings, you can use this button. Changing the ezTCP configuration details if a password has been entered requires the proper password to be entered in the PASSWORD field.

√ *If you forget the password, erase or reenter in Console Mode.*



This button is used to read a dynamic status during operating ezTCP. Pressing this button will display a new window, where the time-elapsed after the power is on, the current IP address, and the data throughput of the serial port are indicated. Double-clicking each item on the [Search List] will carry out the same function.

4.2.2. Example configuration of ezConfig

ezConfig can be used to change the IP address related items, the serial port setup value, the serial port operation mode, and how to setup ezTCP. This section describes these functions briefly. For more information, see the following sections.

The following example shows how to read and change ezTCP's basic functions. Try changing ezTCP setup value according to the following sequence:

- When the ezTCP power is turned on and the LAN cable is connected correctly, pressing [Search] or [Read] button will display the following window:

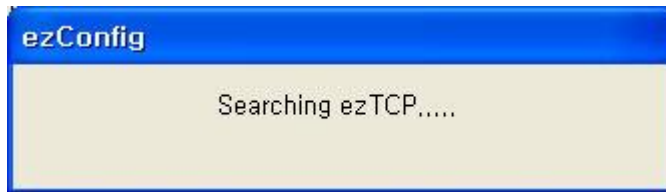

- If a network-attached ezTCP is detected, the following message will be displayed. If a message pops up indicating that there is no response from ezTCP, check that the power is turned on and the cable is connected correctly, then try pressing [Search] or [Read] button.

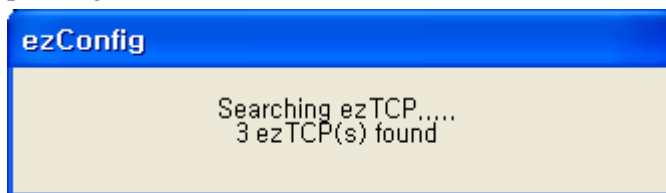

√ *It is impossible to use ezConfig, if EZCFG check box is disabled. This function can be re-enabled in Console mode.*

- If more than one ezTCP are detected, ezTCP's MAC ADDRESS will be displayed in the [Search List] box on ezConfig. Check if the MAC ADDRESS displayed in the [Search List] window corresponds to that printed on ezTCP main body. The following screen shows this process:
- Set [ezTCP Mode], [Local IP Address], [Local Port], and serial port related items. After setting press [Write] button. If there is any error during writing process, check the LAN between PC and EZL-200F.
- Check if the set IP address is correct with ping command in DOS prompt. Following is the message if the IP address is OK. If "Request timed out" message is shown, check IP address.

```
C:\>ping a.b.c.d
Pinging a.b.c.d with 32 bytes of data:
Reply from a.b.c.d: bytes=32 time=1ms TTL=64
Reply from a.b.c.d: bytes=32 time=1ms TTL=64
Reply from a.b.c.d: bytes=32 time=1ms TTL=64
Reply from a.b.c.d: bytes=32 time=1ms TTL=64
```

<When IP address is a.b.c.d.>

√ *IP address, subnet mask, and gateway IP address of both PC and EZL-200F should be correct to succeed in ping test.*

4.3. Configuration using Telnet

You can configure the environmental variables for Telnet connection, using Telnet client in your Windows or Linux or using a terminal like Teraterm Pro.

√ *If Telnet checkbox in ezConfig items is not checked, you cannot log in Telnet. To use Telnet function, enable Telenet function in console mode or using ezConfig program.*

4.3.1. Example of Configuration using Telnet

The following section describes the process of configuring the environmental variables using Telnet.

The environment used here for an example is as follows.

	PC	EZL-200F
Operating System	Windows XP Korean	-
Application	Telnet	-
Local IP Address	10.1.0.2	10.1.0.1
Subnet mask	255.0.0.0	255.0.0.0
Gateway IP address	10.1.0.254	10.1.0.254

- Click “Run” in the Start menu of Windows, and the Run window appears.
Enter “cmd” in the Run window (If the OS is Windows 98, enter “command”).

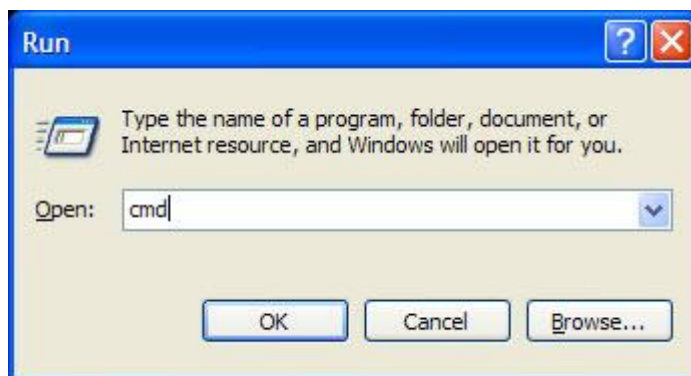

- Then, the DOS window appears. Enter “Telnet 10.1.0.1” in the DOS window, and click “Enter”.

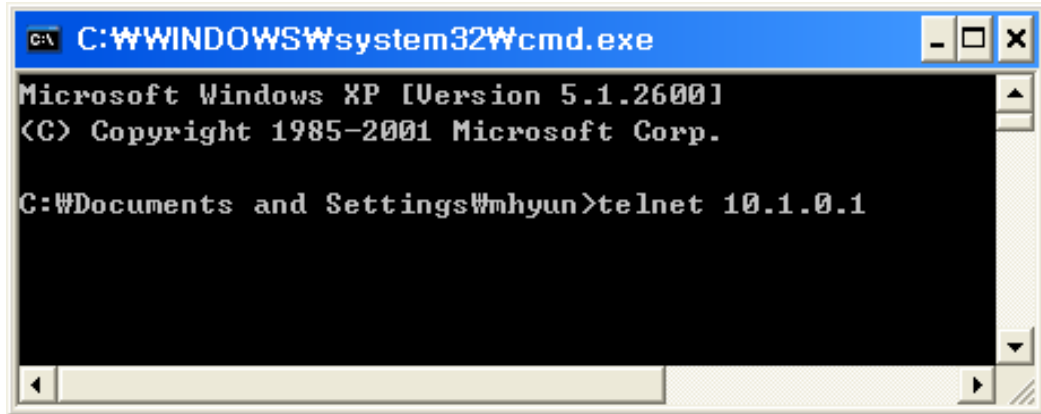

```
C:\WINDOWS\system32\cmd.exe
Microsoft Windows XP [Version 5.1.2600]
(C) Copyright 1985-2001 Microsoft Corp.

C:\Documents and Settings\mhyun>telnet 10.1.0.1
```

- When the following message is displayed, Telnet connection is successfully established.

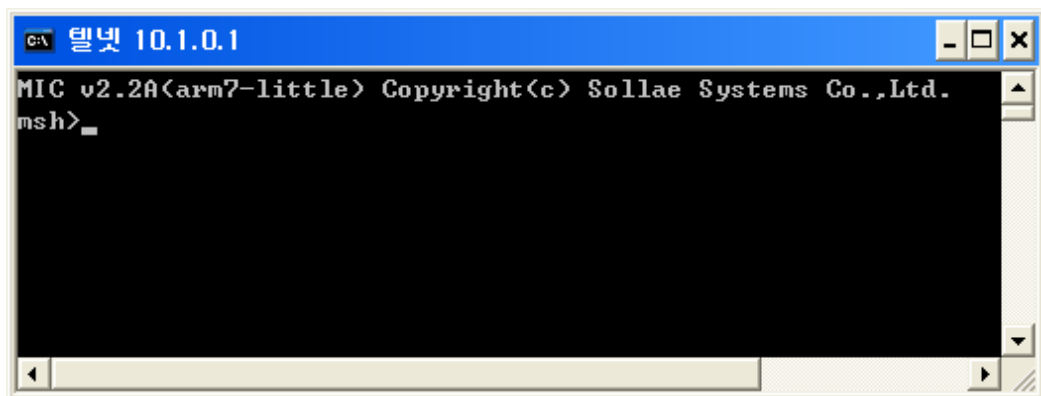

```
텔넷 10.1.0.1
MIC v2.2A(arm7-little) Copyright(c) Sollae Systems Co.,Ltd.
msh>
```

- If a password has been set to EZL-200F, Telnet connection is established only when the password is entered.

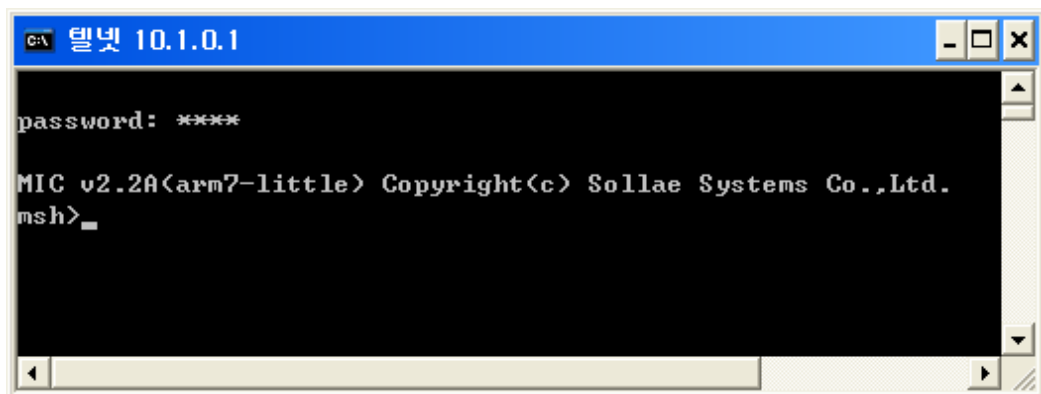

```
텔넷 10.1.0.1
password: ****
MIC v2.2A(arm7-little) Copyright(c) Sollae Systems Co.,Ltd.
msh>
```

- The following is a screen for setting the IP address related items.

```

c:\ 텔넷 10.1.0.1
MIC v2.2A<arm7-little> Copyright(c) Sollae Systems Co.,Ltd.
msh>env if
MAC ADDR < 00:30:f9:00:00:05>
EZCFG < Yes>
ARP < Yes>
DHCP < No>
PPPOE < No>
LOCAL IP < 10.1.0.1>
SUBNET MASK < 255.0.0.0>
GATEWAY < 0.0.0.0>
msh>_

```

- The following is a screen for setting the serial port related items and the TCP port related items.

```

c:\ 텔넷 10.1.0.1
MIC v2.3A<arm7-little> Copyright(c) Sollae Systems Co.,Ltd.
msh>env ez1
MULTI.CONN < No>
SERIAL TYPE < 0>
BAUD RATE < 115200>
PARITY < 0>
DATA BITS < 8>
RTSCTS < No>
XON/XOFF < No>
TELNET < Yes>
MUX TYPE < 0>
TIME OUT < 0>
LOCAL PORT < 1470>
PEER IP < 0.0.0.0>
msh>_

```

- The following is a screen for setting SSL and other items.

```

C:\ 텔넷 10.1.0.1
msh>env ext
COMMENT < >
SSL < No>
SSH < No>
TELCOM < No>
CONN MAC ID < No>
SLIP < No>
SEND DELAY < 0>
COD DELAY < 0>
msh>_

```

- The following is a screen for setting a password.

```

C:\ 텔넷 10.1.0.1
msh>env pwd
PASSWORD < no passwd>
msh>

```

4.3.2. Configuration Commands by telnet

command	Item	Description
env if	MAC ADDR	Fixed
	EZCFG	Enable ezConfig function.
	ARP	Enable IP setting by ARP.
	DHCP	Select to receive EZL-200F IP address as DHCP.
	PPPOE	Select to receive EZL-200F IP address as PPPoE.
	LOCAL IP	IP address of EZL-200F
	SUBNET MASK	Subnet mask
env ezl	GATEWAY	IP address of gateway
	BAUD RATE	Serial port speed (bps)
	PARITY	Parity
	DATA BITS	Data bit length
	RTSCTS	Flow control
	TELNET	Enable Telnet log in function

	MUX TYPE	Communication Mode (0: T2S, 1: ATC, 2: COD, 3: U2S)
	TIME OUT	T2S, ATC, COD: Limit Time to Keep Connection (unit: 10ms) U2S: UDP data receiving time from serial port for a block (unit: 10ms)
	LOCAL PORT	Local Port Number
	WATER MARK	COD: Minimum number of bytes attempting to connect(unit: byte) U2S: UDP block size (unit: byte)
	PEER IP	T2S: connection permitted peer IP address (when 0.0.0.0, any host can connect) COD: IP address to connect in Client mode U2S: UDP datagram destination IP address
	PEER PORT	ATC, COD: connection port number U2S: UDP datagram destination Port number
env pwd	Password for telnet login and ezConfig. For erasing, input ‘.’.	
env ext	COMMENT	User specific information(maximum: 32bytes)
	SSL	Enabling SSL function
	SSH	Enabling SSH function
	TELCOM	Enabling Telnet COM Port Option
	CONN MAC ID	Enabling MAC address transmission function
	SLIP	Enabling simple router function by SLIP
	SEND DELAY	TCP data transmitting time (unit: ms)
	COD DELAY	Reconnection time when disconnected in COD Mode. (unit: second)

√ *If any item is modified, the item is saved and reboot automatically.*

√ *After setting IP address successfully by telnet but IP address is not set correctly, turn off ARP function.*

4.4. AT command

In ATC mode, the user can set environment variables through the serial port using AT

command.

☞ *For more information, See “7. ATC Mode”.*

4.5. Setting IP address by ARP

If ARP function is enabled, EZL-200F saves the destination IP address of the first packet which incomes to its MAC address as its local IP address to its volatile memory. By using this function, user can set IP address of EZL-200F.

On Windows and UNIX(Linux) platform, the command ‘arp’ enables a user to change the contents of arp cache table from the host computer. After changing the contents of the arp cache table, attempting a Telnet connection or a ping test will change the ezTCP’s IP address. IP address changed by the arp command will not be stored in EEPROM. Therefore, the user should change the IP-related items by giving “env if” command through telnet access. ezTCP allows the user to change the IP address only one time after the power is turned on.

The example listed below shows how to change the arp cache table on Windows’ MS-DOS prompt window and Linux. If ezTCP’s Ethernet address is 00:30:f9:00:00:01 and the IP address to use is a.b.c.d., the user can change the IP address as follows:

4.5.1. Setting of EZL-200F’s IP address in Windows

```
C:\>arp -s a.b.c.d 00-30-f9-00-00-01 ☞ modifying table
C:\>arp -a ☞ confirming modification
Interface: xxx.xxx.xxx.xxx on Interface xxxxxxxx
Internet Address    Physical Address    Type
a.b.c.d            00-30-f9-00-00-01  static
C:\>ping a.b.c.d ☞ ping test (after resetting EZL-200F)
Pinging a.b.c.d with 32 bytes of data:
Reply from a.b.c.d: bytes=32 time=1ms TTL=64
Reply from a.b.c.d: bytes=32 time=1ms TTL=64
Reply from a.b.c.d: bytes=32 time=1ms TTL=64
Reply from a.b.c.d: bytes=32 time=1ms TTL=64
C:\>
```

4.5.2. Setting of EZL-200F’s IP address in Linux

```
rtos:~>arp -s a.b.c.d 00:30:f9:00:00:01 ☞ modifying table
```

```
rtos:~>arp 👁 confirming modification
Address      Hwtype  Hwaddress  Flags Mask Iface
a.b.c.d      ether   00:30:f9:00:00:01  CM      eth0
rtos:~>ping a.b.c.d 👁 ping test (after resetting EZL-200F)
Pinging a.b.c.d with 32 bytes of data:
Reply from a.b.c.d: bytes=32 time=1ms TTL=64
Reply from a.b.c.d: bytes=32 time=1ms TTL=64
Reply from a.b.c.d: bytes=32 time=1ms TTL=64
Reply from a.b.c.d: bytes=32 time=1ms TTL=64
rtos:~>
```

√ *Modified IP address store its new IP address to its volatile memory, so user should login and change IP address if you would change IP address permanently.*

4.6. Setting IP Address-related Items by DHCP

Under environment with a network operating a DHCP server, DHCP protocol allows the user to automatically set the IP address, subnet mask, gateway, and name server of ezTCP. Using DHCP automatic setup function requires the user to check [DHCP] item on ezConfig. Note that the user may have to check [ARP] item according to the type of DHCP servers.

4.7. Setting IP Address-related Items by PPPoE

PPPoE is used in most ADSL and VDSL. To use PPPoE function, PPPoE function should be enabled and PPPoE ID and PPPoE password should be configured. The local IP address of EZL-200F is assigned automatically in PPPoE environment.

√ *Some ADSL or VDSL modem use DHCP. Please contact your ISP (Internet Service Provider).*

5. Operation Mode

5.1. Operation Mode Overview

5.1.1. Overview

EZL-200F can operate in one of three modes (normal, console, and ISP modes). Normal mode is ordinary data communication mode; console mode is used to configure the environmental variables through the serial port; and ISP mode is used to download EZL-200F firmware through the serial port.

5.2. How to Initiate Each Operation Mode

5.2.1. How to Initiate Normal Mode

Normal mode is a mode in which EZL-200F performs its original functions. If you do not make any change in the default setting, EZL-200F usually operates in normal mode.

☞ *For more information, see “6. Normal Communication Mode.”*

5.2.2. How to Initiate Console Mode

Press and hold the ISP button on the back of the product for one second, EZL-200F operation mode is switched to console mode.

In console mode, you can configure EZL-200F through the serial port in RS232 communication mode. At this time, the RS232 port operates in the following conditions: 19200 bps, 8 data bits, no parity, 1 stop bit, and no flow control.

When console mode is initiated, the following message is displayed.

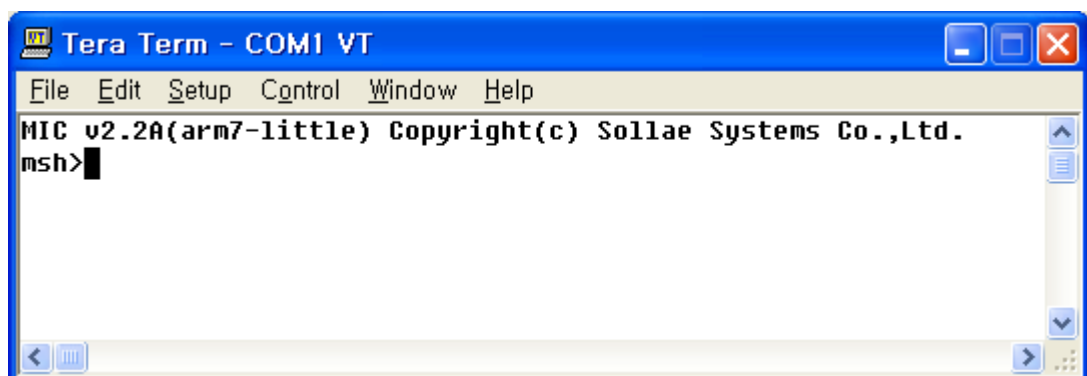

```
Tera Term - COM1 VT
File Edit Setup Control Window Help
MIC v2.2A(arm7-little) Copyright(c) Sollae Systems Co.,Ltd.
msh>
```

5.2.3. How to Initiate ISP Mode

Connect the serial port of EZL-200F to a PC or a notebook, run serial communication program (Teraterm, etc.) using which you can send binary data, and then configure the serial port as follows: 115200 bps, 8 data bits, no parity, 1 stop bit, no flow control. Supply power to EZL-200F with pressing the ISP button on the back of the product, and EZL-200F operates in ISP mode. The following is the message displayed on the serial terminal when EZL-200F is connected to the serial port in ISP mode.

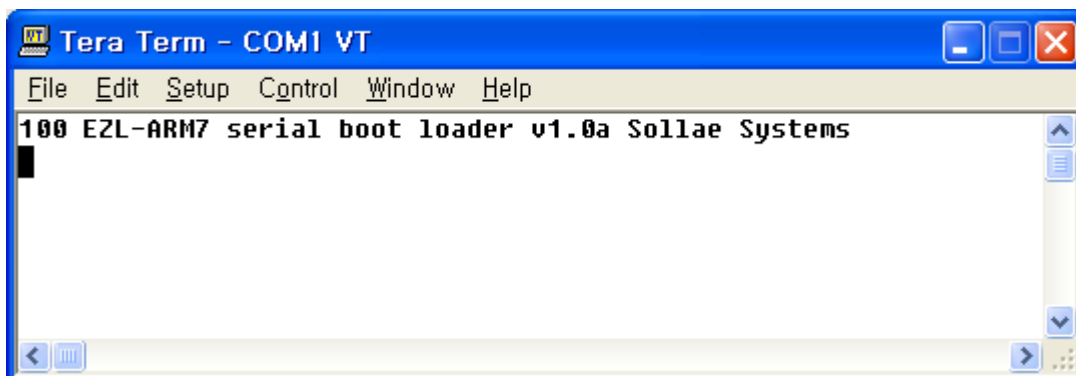

5.2.4. Comparison of Operation Modes

The following table is the comparison of the above described operation modes.

Mode	How to Initiate	Description	Serial Port Communication Speed
Normal	-	Normal data communication mode T2S, ATC, COD, U2S	User setting
Console	Press and hold the button for 1 second in normal mode.	Configure the environmental variables and disable the security function, through the serial port.	19200bps,N,8,1
ISP	Supply power with pressing the button.	Download firmware through the serial port (Ethernet does not work).	115200bps,N,8,1

5.3. Normal Communication Mode

Normal communication mode is suitable for the purpose of using EZL-200F.

Normal communication mode can be classified into four modes – T2S, ATC, COD, and U2S – each of which is described in the following table.

Communication Mode	Protocol	Connection	Need for User Equipment Software Modification	Configuration of Environmental Variables through Serial Port	Topology
T2S	TCP	Passive Connection	Not needed	Impossible	1:1
ATC	TCP	Active/Passive Connection	Needed	Possible	1:1
COD	TCP	Active Connection	Not needed	Impossible	1:1
U2S	UDP	No Connection	Not needed	Impossible	N:M

TCP protocol requires connection process. The connection is always established as 1:1 connection. At this time, the host waiting for connection (passive connection) is called a server and the one attempting to connect (active connection) is called a client.

On the other hand, UDP communicates by block unit without connection process. As UDP does not require connection, numbers of hosts can communicate at the same time.

☞ *For more information on communication modes, refer to the next chapter.*

5.4. Console Mode

In console mode, you can configure the environmental variables of ezTCP and all security functions are disabled. Therefore, whether you choose or not, ezConfig and Telnet functions are enabled. If you have lost your password, you can remove or change the password in this mode.

Communication Speed	19200 bps
Parity Type	no parity
Data Bits	8 bits
Stop Bit	1 stop bit

☞ *Commands used in console mode are the same as those set after logging in Telnet. So, refer to “4.3 Configuring using Telnet”.*

5.5. ISP Mode

In ISP mode, you can download the latest firmware (EZL-200F operation software) provided by our company.

Communication Speed	115200 bps
Parity Type	no parity
Data Bits	8 bits
Stop Bit	1 stop bit

The following section describes how to download firmware in ISP mode.

- Set the serial terminal through which you can transmit binary data as shown above, and connect the supplied serial cable. Supply power to EZL-200F with pressing the ISP button on the back of the product. Then, the following message is displayed on the serial terminal.

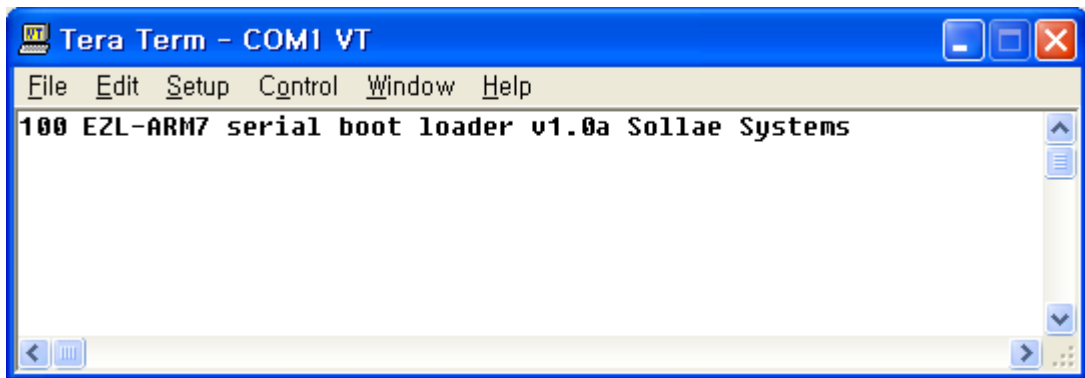

- Enter the program command 'p', and press the Enter key. Then, the following message is displayed.

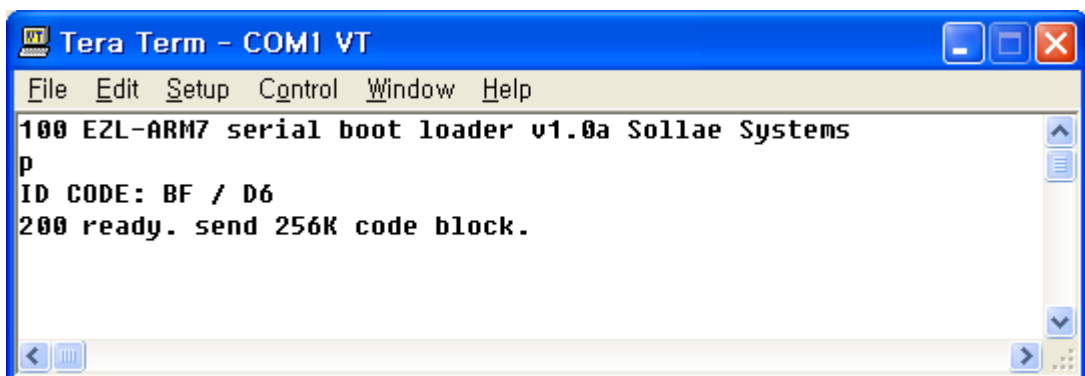

- Firmware to be downloaded is transmitted. The following is a screen displayed when the firmware is normally transmitted to EZL-200F and saved in its flash

memory without an error.

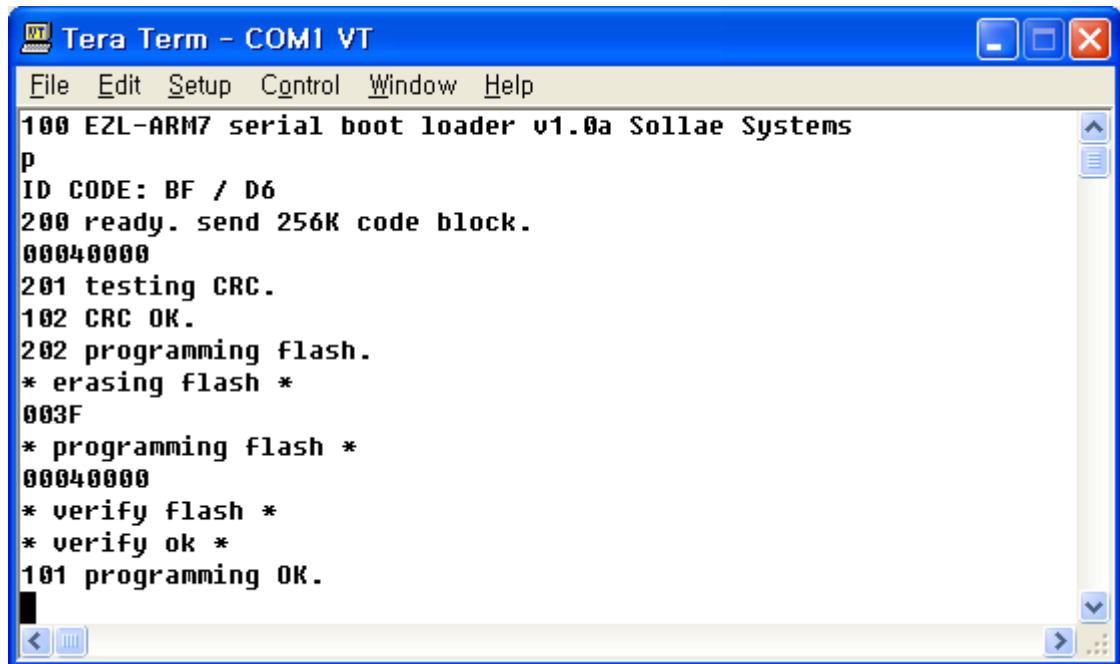

```
File Edit Setup Control Window Help
100 EZL-ARM7 serial boot loader v1.0a Sollae Systems
p
ID CODE: BF / D6
200 ready. send 256K code block.
00040000
201 testing CRC.
102 CRC OK.
202 programming flash.
* erasing flash *
003F
* programming flash *
00040000
* verify flash *
* verify ok *
101 programming OK.
```

- When downloading is completed, turn off the power and then turn it on again.

√ *You can also download firmware over Ethernet after logging in Telnet. For more information, refer to the supplied application note.*

6. Normal Communication Mode

6.1. T2S (TCP To Serial)

In T2S mode, the ezTCP functions as a server.

When a host connect to predefined local port, the ezTCP accepts a TCP connection. When the ezTCP accepts TCP connection, then the TCP connection is established. After connection is established, TCP/IP processing is performed on the data coming to the serial port, which is then transmitted to the remote host. And the TCP/IP data coming from the remote host is TCP/IP-processed and transmitted to the serial port to establish data communication. (Data coming to the serial port before TCP connection is established will be ignored.)

To limit the peer host, user should set [Peer IP Address]. The only pre-defined host can be accessible. If [Peer IP Address] is 0.0.0.0, any host can connect to EZL-200F.

If Multi Conn. Function is enabled, Maximum 8 hosts connect to EZL-200F. All hosts which are connected communicate with EZL-200F.

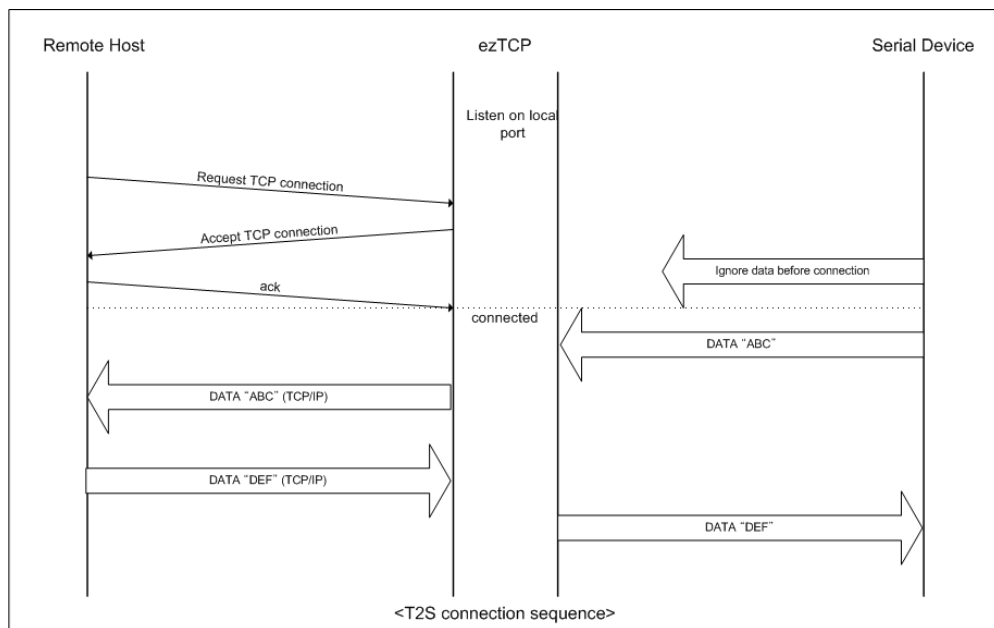

Set the following for T2S mode:

	Item	Description
IP Address Related Items	Local IP Address	IP address of EZL-200F
	Subnet Mask	Subnet mask
	Gateway IP Address	IP address of gateway
	Local Port	Port number for waiting to be connected in Server mode
	Peer IP Address	Permitted host to connect (if set to 0.0.0.0, any host can connect)
	DHCP	Select to receive EZL-200F IP address as DHCP.
	PPPoE	Select to receive EZL-200F IP address as PPPoE.
Serial Port	Serial Type	Serial port type
	Baudrate	Serial port speed (bps)
	Data bits	Data bit length
	Parity	Parity
	Stop bit	Stop bit
	Flow Control	Flow control
Communication Mode	ezTCP Mode	Communication Mode (T2S(0))
	SSL	Enabling SSL function
	Multi Conn.	Multiple connection up to 8 (SSL is not supported when Multi Conn. Is enabled)
	TELCOM	Enable Telnet COM Port Option
	MAC ID	Enable MAC address transmission function
Disconnection	Timeout	Limit time to keep connection
Configuration Method	ezConfig	Enable ezConfig function.
	Telnet	Enable Telnet log in function
	SSH	Enable SSH log in function
	Password	Set Telnet, SSH and ezConfig password.
	ARP	Enable IP setting by ARP.

6.2. ATC (AT Command)

In ATC mode, the user can control the ezTCP in a similar way to controlling the modem using AT command. In ATC mode, only a TCP connection is possible and both the server and the client can be configured.

In ATC mode, the AT command allows the user to set environment variables including the IP address and control TCP connection and disconnection.

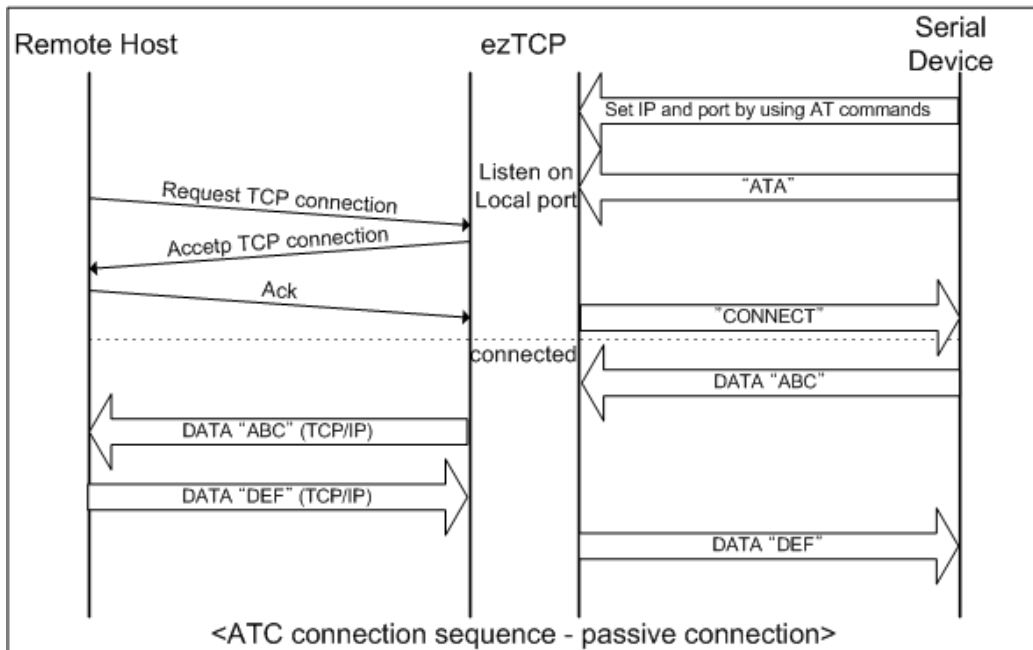
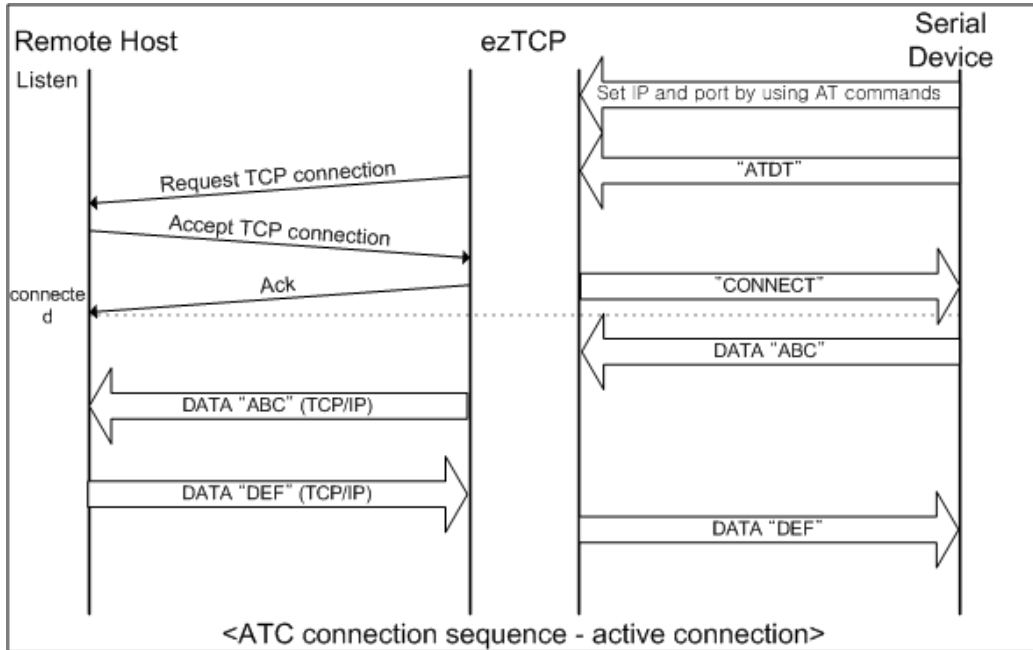

Set the following for ATC mode.

	Item	Description
IP Address Relate Items	Local IP Address	IP address of EZL-200F
	Subnet Mask	Subnet mask
	Gateway IP Address	IP address of gateway
	Local Port	Port number for waiting to be connected in Server mode
	Peer IP Address	Peer IP address to connect
	Peer Port	Peer port number to connect
	DHCP	Select to receive EZL-200F IP address as DHCP.
	PPPoE	Select to receive EZL-200F IP address as PPPoE.
Serial Port	Serial Type	Serial port type
	Baudrate	Serial port speed (bps)
	Data bits	Data bit length
	Parity	Parity
	Stop bit	Stop bit
	Flow Control	Flow control
Communication Mode	ezTCP Mode	Communication mode(ATC(1))
	SSL	Enabling SSL function
Disconnection	Timeout	Limit time to keep connection
Configuration Method	ezConfig	Enable ezConfig function.
	Telnet	Enable Telnet log in function
	SSH	Enable SSH log in function
	Password	Set Telnet, SSH and ezConfig password.
	ARP	Enable IP setting by ARP.

☞ See the next chapter

6.3. COD (Connect On Demand)

In COD mode, the ezTCP functions as a client.

When data of the pre-specified size [CONN BYTE] comes to the serial port, the ezTCP attempts a TCP connection to the TCP port [PEER PORT] of the preset host IP [PEER IP ADDRESS]. If the remote host accepts the TCP connection, TCP connection will be established. Data coming to the serial port after connection establishment is TCP/IP-processed and transmitted to the remote host. And, data coming from the remote host is TCP/IP-processed and transmitted to the serial port for data communication.

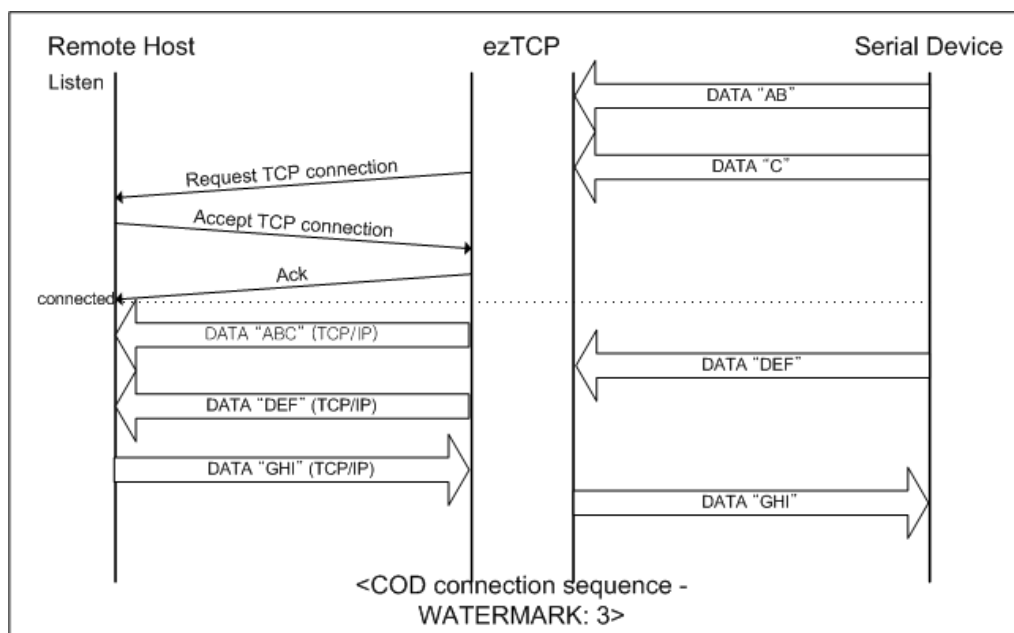

Set the following for COD mode.

	Item	Description
IP Address Related Item	Local IP Address	IP address of EZL-200F
	Subnet Mask	Subnet mask
	Gateway IP Address	IP address of gateway
	Peer IP Address	Peer IP address to connect
	Peer Port	Peer port number to connect
	DHCP	Select to receive EZL-200F IP address as DHCP.
	PPPoE	Select to receive EZL-200F IP address as PPPoE.
Serial Port	Serial Type	Serial port type
	Baudrate	Serial port speed (bps)
	Data bits	Data bit length
	Parity	Parity
	Stop bit	Stop bit
	Flow Control	Flow control
Communication Mode	ezTCP Mode	Communication mode(COD(2))
	SSL	Enabling SSL function
	TELCOM	Enabling Telnet COM Port Option
	MAC ID	Enabling MAC Address Transmission function
Connection/ Disconnection	Conn. Byte	Bytes for starting to connect
	Timeout	Limit time to keep connection
Configuration Method	ezConfig	Enable ezConfig function.
	Telnet	Enable Telnet log in function
	SSH	Enable SSH log in function
	Password	Select between Telnet password and ezConfig password.
	ARP	Enable IP setting by ARP.

6.4. U2S (UDP To Serial)

U2S mode allows for UDP communication.

In UDP mode, data are transmitted in blocks, which requires dividing data coming to the serial port into blocks before transmitting data. A procedure for dividing data into blocks is as follows:

If data of pre-specified bytes [Conn. Byte] comes to the serial port of the ezTCP or if a specified period of time [TIMEOUT] elapses after first data reception, all data received for the same period is recognized as one block which is then transmitted to the UDP. The [TIMEOUT] unit is 10ms. If [TIMEOUT] is set to 2, the time period is between 20ms and 30ms.

Since UDP communication does not require a connection procedure, the user can establish N-to-M communication via multicast and broadcast.

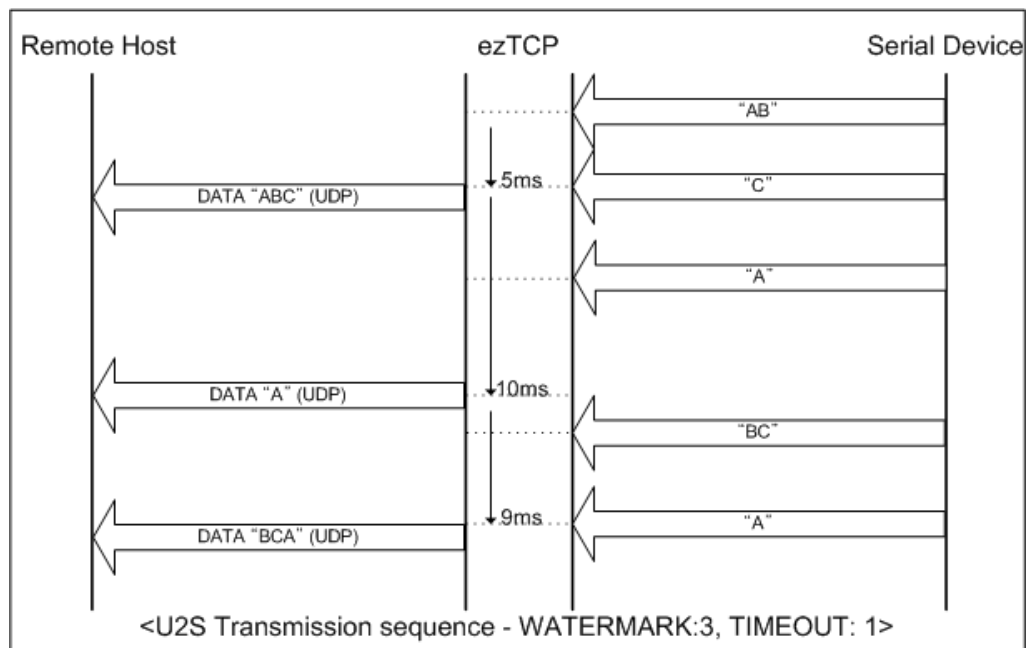

√ *SSL protocol cannot be used in U2S, because SSL works over TCP.*

Set the following for U2S mode.

	Item	Description
IP address Related Item	Local IP Address	IP address of EZL-200F
	Subnet Mask	Subnet mask
	Gateway IP Address	IP address of gateway
	Local Port	Port number for UDP data receiving
	Peer IP Address	Peer IP address to transmit
	Peer Port	Peer port number to transmit
Serial Port	Serial Type	Serial port type
	Baudrate	Serial port speed (bps)
	Data bits	Data bit length
	Parity	Parity
	Stop bit	Stop bit
	Flow Control	Flow control
Communication Mode	ezTCP Mode	Communication mode(U2S(3))
Packets	Block	UDP block size to transmit (unit: byte)
	Interval	Data gathering time from serial port to transmit as UDP (unit:10ms)
Configuration Method	ezConfig	Enable ezConfig function.
	Telnet	Enable Telnet log in function
	SSH	Enable SSH log in function
	Password	Select between Telnet password and ezConfig password.
	ARP	Enable IP setting by ARP.

7. ATC Mode

7.1. Overview

EZL-200F can be controlled by AT commands in ATC mode. For example, the peer host IP address can be set by AT+PRIP command and connect to the host by ATD command.

Therefore, EZL-200F communicates several hosts alternatively.

And also, it provides passive connection function by ATA command.

7.1.1. AT command format

AT commands start with AT, and end <CR>.

AT command format is followed.

AT	Command	<CR>(0x0d)
----	---------	------------

The response code to AT command is followed.

Response message	<CR>(0x0d)	<LF>(0x0a)
------------------	------------	------------

Response Message

When ATV1 (initial setting)	When ATV0	Description
OK	0	command OK
CONNECT	1	TCP connected
NO CARRIER	3	TCP disconnected
ERROR	4	Command error
Set value	Set value	When query set value (example: AT+PRIP?)

7.2. Basic AT Command Set (Example: ATA, ATD etc.)

Command	Function	Description
A	passive connection	Listen connection (host → EZL-200F connection)
D	active connection	Connecting to host form EZL-200F
E	echo	Echo (E0 – no echo, E1-echo)
H	off-hook	disconnection
I	Inquiry	Output EZL-200F related-information
O	Online	To online mode
V	enable result code	Result code (numeric-V0, alphabetic-V1)

Z	reset	Reset
---	-------	-------

7.3. Extended AT Commands (Example: AT+PLIP etc.)

Command	Function	Description
+PLIP	local IP address	
+PSM	subnet mask	
+PGIP	default router	
+PLP	listening TCP port	
+PTO	timeout	
+PRIP	Remote machine IP address	
+PRP	Remote machine TCP port	
+PWP	Write configuration	Saving and Reset
+PRC	ezConfig enable/disable	ON: 1, OFF: 0
+PARP	ARP setting function enable/disable	ON: 1, OFF: 0
+PDC	DHCP enable/disable	ON: 1, OFF: 0

7.4. Online State and Online Command State

It is online command mode during disconnected. AT commands can be used in online command mode. After TCP connection, AT commands cannot be used. To use AT commands during the connection, change state to online command state.

Online Command State	During TCP disconnected, AT commands can be used To use AT commands during the connection, required escape sequence
Online State	During TCP connected, all serial data to EZL-200F convert TCP and send to ethernet

7.4.1. Changing Online State to Online Command State

To change online state to online command state during the connection, +++ string should be transmitted to EZL-200F as following time interval.

When transmitting +++ string to EZL-200F, +++ string will be sent to peer host.

The time from final data the first '+' data of	No data over 500ms(guard time)
--	--------------------------------

'+++ ' string	
time intervals between '+'s	0~500ms
Time interval after receiving last '+'	No data over 500ms (guard time)

7.4.2. Changing Online Command State to Online State

If EZL-200F's state is in online command state during TCP connection, EZL-200F's state can be changed into online state by an ATO command.

7.5. Example of Configuration with AT Command

	Serial Port		Description
	AT+PLIP=192.168.1.200<CR>	▶	Setting LOCAL IP address
◀	<CR><LF>OK<CR><LF>		Command OK
	AT+PGIP=192.168.1.254<CR>	▶	Setting GATEWAY IP address
◀	<CR><LF>OK<CR><LF>		Command OK
	AT+PSM=255.255.255.0<CR>	▶	Setting SUBNET MASK
◀	<CR><LF>OK<CR><LF>		Command OK
	AT+PLP=1470<CR>	▶	Setting LOCAL PORT
◀	<CR><LF>OK<CR><LF>		Command OK
	AT+PTO=10<CR>	▶	Setting TIME OUT
◀	<CR><LF>OK<CR><LF>		Command OK
	AT+PWP<CR>	▶	Saving setting value to EEPROM Reset automatically
◀	<CR><LF>OK<CR><LF>		Command OK
◀	<CR><LF>NO CARRIER<CR><LF>		System Reset

7.6. Example of TCP Connection

7.6.1. Example of Active Connection

	Serial Port		Description
	AT+PRIP=192.168.1.201<CR>	▶	Setting remote IP address to connect
◀	<CR><LF>OK<CR><LF>		Command OK
	AT+PRP=1470<CR>	▶	Setting remote port number to connect
◀	<CR><LF>OK<CR><LF>		Command OK
	ATDT<CR>	▶	Connecting to the host

Attempting to connect to the host		
◀	<CR><LF>CONNECT<CR><LF>	TCP connection success
Data Communication		

7.6.2. Example of passive Connection

	Serial Port		Description
	AT+PLP=1470<CR>	▶	Set LOCAL PORT to listen
◀	<CR><LF>OK<CR><LF>		Command OK
	ATA<CR>	▶	Passive connection command
Listen on local port from a host			
A host connects to EZL-200F			
◀	<CR><LF>CONNECT<CR><LF>		TCP connection OK
Data Communication			

7.7. Example of TCP Disconnection

7.7.1. Example of active disconnection

EZL-200F disconnects the connection.

	Serial Port		Description
Data Communication(during TCP connection)			
	[guard time]+++[guard time]	▶	Changing online state to online command state
◀	<CR><LF>OK<CR><LF>		Changed to online command state
	ATH	▶	TCP disconnection command
◀	<CR><LF>OK<CR><LF>		Command OK

7.7.2. Example of passive disconnection

The remote host disconnects the connection.

	Serial Port		Description
Data Communication(during TCP connection)			
The remote host disconnect the connection			
◀	<CR><LF>NO CARRIER<CR><LF>		TCP disconnected

8. Other Functions

8.1. SSL

Secure Socket Layer (SSL) is a security protocol used in the Internet environment that requires security feature. As being a protocol operating at high layer of TCP, SSL cannot be used in U2S that uses UDP.

Though it is possible to use SSL in client mode, it is necessary to make some changes on the console in server mode.

For more information about how to use SSL, refer to the SSL application note provided on our company's web site.

8.2. SSH

SSH(Secure Shell) strengthen security when user login the EZL-200F. When SSH is enabled, telnet is disabled and user have to log in by an SSH client.

To enable SSH function, login and put 'env ext' function and press 'y' for the SSH. And then, user have to input 'dsa keygen' to generate key.

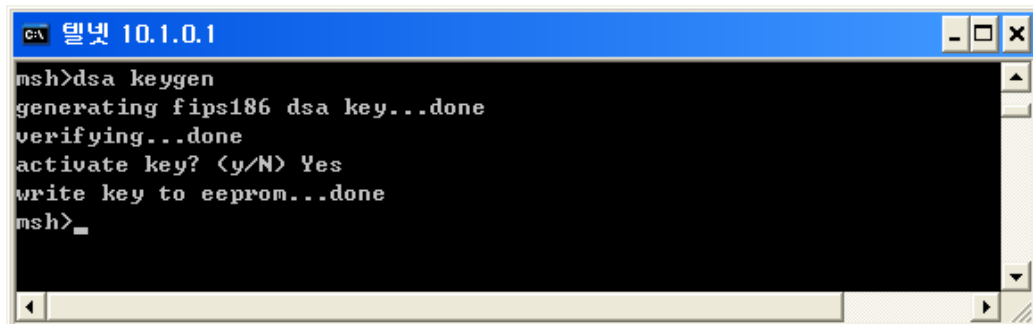

```
C:\> 텔넷 10.1.0.1
msh>dsa keygen
generating fips186 dsa key...done
verifying...done
activate key? (y/N) Yes
write key to eeprom...done
msh>_
```

The ID is 'admin' and the password is the password for telnet or ezConfig.

8.3. Telnet COM Port Option

EZL-200F transmits RXD and TXD data from or to its serial port basically. But sometimes user need to transmit its control signals (RTS, CTS, DTR, DSR). The transmission function is defined in the RFC2217 by telnet protocol. EZL-200F also provides Telnet COM Port Option defined in the RFC2217.

To enable the Telnet COM Port Option, login EZL-200F and input 'env ext' and press 'y' for TELCOM.

8.4. Ping Test

On EZL-200F console, you can test ping from EZL-200F to another host. Ping test command format is as follows.

Ping	<SP>	IP Address	<SP>	count
------	------	------------	------	-------

- IP Address

IP address of the host from which ping test is to be performed

- count

Ping test count. This item can be omitted. In this case, ping test is performed 4 times as default.

√ *It is impossible to stop ping test in the middle of it.*

8.5. Designating TCP Tx Block

Since TCP transmits data in stream while UDP transmits data by block unit, the order in which data is received is important but the transmitted block size does not mean anything. EZL-200F gathers data coming through the serial port for at least 20ms and then transmits it to the network (the time for gathering and sending data is called nagle time).

Therefore, if your host program is made to process TCP data by block unit, communication may not be smooth. The best way to solve this problem is to modify the host program to receive data in stream.

However, it is impossible to modify the host program, you can change nagle timer value of EZL-200F to gather data for a certain period of time.

To change the nagle timer, open EZL-200F console, enter “env ext” command, and then change “SEND DELAY” item (unit: ms)

√ *If the nagle timer is changed, data is gathered for the period of time set to the nagle timer. But, if packets are lost on the network, the lost packets and new data from the serial port are all sent together and thus data much larger than the expected size may have to be transmitted.*

8.6. Setting COD Delay in COD Mode

If Conn. Byte is 0 in COD mode, EZL-200F attempts to connect to the pre-set host as soon as it is started. If connection is off after normal connection has been established, EZL-200F attempts to reconnect the host, usually after 10 second delay.

In order to control the delay time, open EZL-200F console, enter “env ext” command, and then change “COD DELAY” item (unit: second)

√ *If COD DELAY is set to 0, the default delay time is 10. If it is set to a value other than 0, the value is the delay time.*

8.7. Multi-connection

When EZL-200F operates in T2S mode, maximum 8 hosts can connect at the same time. All the connected hosts can communicate in both ways. Multi-connection can be useful when several hosts monitor one equipment. When multi-connection is enabled, SSL cannot be used. In addition, only RS232 serial port can be used and flow control cannot be used.

8.8. SLIP Function

EZL-200F operates as a simple router with its serial port. So user can connect two networks with two EZL-200Fs. EZL-200F process only IP data grams.

8.8.1. Configuring SLIP

To set the SLIP function, login EZL-200F and input ‘env ext’ and press ‘y’ for the ‘SLIP’ item. And input IP address to each EZL-200Fs as their networks to be installed.

8.8.2. Configuring Hosts

The gateway IP address of a host that communicates via EZL-200F is the IP address of the EZL-200F. (EZL-200F operates as a simple router.)

9. Technical Support, Warranty, and Notes on Operation

9.1. Technical Support

If you have any question regarding operation of the product, visit Customer Support FAQ corner and the message board on Sollae Systems' web site or send us an email at the following address: support@eztcp.com

Website Address for Customer Support:

<http://www.sollae.co.kr/Support/index.html>

9.2. Warranty

9.2.1. Refund

Upon the customer's request to refund the product within two weeks after purchase, Sollae Systems will refund the product.

9.2.2. Free Repair Services

For product failures occurring within one year after purchase, Sollae Systems provides free repair services or exchange the product. However, if the product failure is due to user's fault, repair service fees will be charged or the product will be replaced at user's expense.

9.2.3. Charged Repair Services

For product failures occurring after the warranty period (one year) or resulting from user's fault, repair service fees will be charged and the product will be replaced at user's expense.

9.2.4. Notes on Operation

- Sollae Systems is not responsible for product failures occurring due to user's alternation of the product.
- Specifications of the product are subject to change without prior notice for performance improvement.

- Sollae Systems does not guarantee successful operation of the product if the product was used under conditions deviating from the product specifications.
- Reverse engineering of firmware and applications provided by Sollae Systems is prohibited.
- Use of firmware and applications provided by Sollae Systems for purposes other than those for which they were designed is prohibited.
- Do not use the product in an extremely cold or hot place or in a place where vibration is severe.
- Do not use the product in an environment in which humidity is high or a lot of oil exists.
- Do not use the product where there is caustic or combustible gas.
- Sollae Systems does not guarantee normal operation of the product under the conditions a lot of noise exists.
- Do not use the product for a purpose that requires exceptional quality and reliability relating to user's injuries or accidents – aerospace, aviation, health care, nuclear power, transportation, and safety purposes.
- Sollae Systems is not responsible for any accident or damage occurring while using the product.

10. Document Revision History

Date	Version	Comment
Jun. 24. 2005	1.2	The first Release
Dec. 05. 2005	1.3	Changed all fonts into Times New Roman Added Revision History
Dec.26.2005	1.4	Added Trash Mark for WEEE
Jan.19.2007	1.5	Add SSH, SLIP, Telnet COM Port Option Add MAC ID function Add Applications
Nov.28.2007	1.6	Correcting Chapter number error in page 34
Jun.04.2008	1.7	Add Mark/Space Parity